

HF
Halogen Free

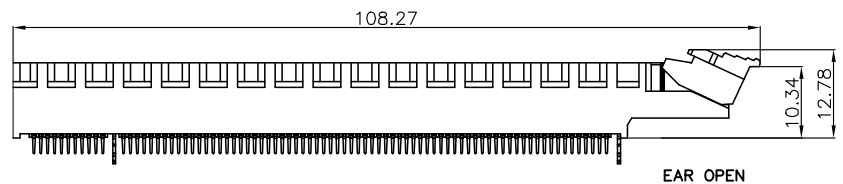

REV.	ECN NO.	LOCATION	DESCRIPTION	DATE	DESIGN
X4			ADD TO LOGO	2021.03.15	Chen
X5			PACKAGING CHANGE	2021.08.19	Chen

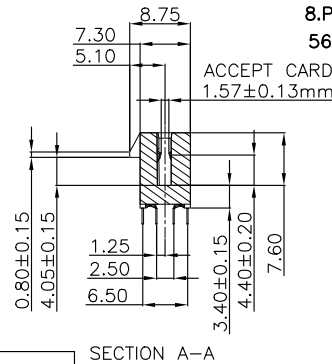
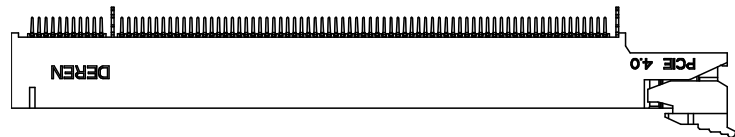
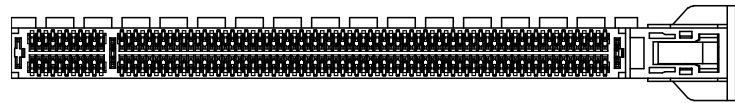
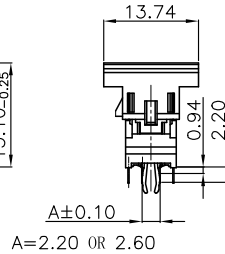
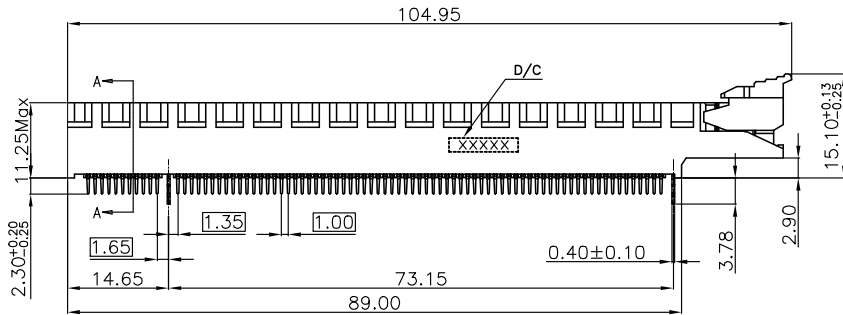
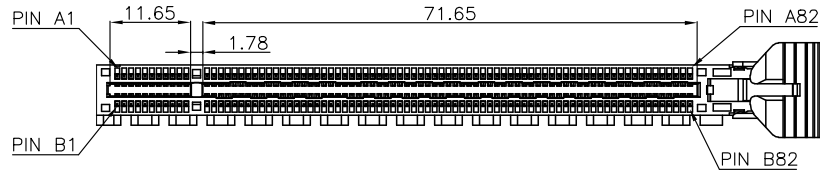

NOTES:

PRODUCT MEETS CONTROLLED SUBSTANCES SPEC. ROHS 2.0

1. MATERIAL:

- 1.1 HOUSING:PA10T+30%G/F, UL94V-0;SEE PART NUMBER.
- 1.2 CONTACT:C5191-EH
- 1.3 LATCH:PA10T, UL94V-0;SEE PART NUMBER
- 1.4 HOOK:SUS304-1/2H T=0.40mm

2. FINISH:

- 2.1 CONTACT:GOLD PLATING(SEE PART NUMBER) ON CONTACT AREA. 2.54um[100u"] MIN. MATTE-TIN PLATING ON SOLDER TAIL AREA.
- 1.27um[50u"] MIN. NICKEL UNDERPLATING OVER ALL.
- 2.2 HOOK:1.27um[50u"] MIN. NICKEL UNDERPLATING OVER ALL 2.54um[100u"] MIN. MATTE-TIN PLATING ON SOLDER TAIL AREA

3.DATE CODE : YYWW (YY: YEAR, WW: WEEK, D: DAY)

4.MECHANICAL CHARACTERISTICS:

- 4-1.CONTACT INSERTION FORCE:1.15N MAX.PER CONTACT PAIR.
- 4-2.DURABILITY:50 MATING AND UNMATING CYCLES.
- 4-3.CONTACT REMOVAL FORCE:0.15N MIN.PER CONTACT PAIR.
- 4-4.CONTACT RETENTION FORCE:4.9N MIN.

5.ENVIRONMENTAL CHARACTERISTICS:

- 5-1.OPERATING TEMPERATURE RANGE:-40°C TO +105°C.

6.RECOMMENDED PROCESS CONDITION:WAVE SOLDER,270°C,5S

7.INSERTION FORCE OF CONN INTO PCB 2kgf MAX.

8.PART NUMBER DESCRIPTION:

564ZD4 - 005H * * * *-PG

- CUSTOMER CODE:
- PACKING CODE:1:TRAY 3:TRAY&MYLAR 2:REEL 4:REEL&MYLAR
- HOUSING COLOR: 1:BLACK 2:WITHE 3.BLUE(659C) 4.GREEN 5.BLACK&BLUE
- TAIL LENGTH CODE:1:2.3mm 2.3.1mm 3.1.80mm 4.3.56mm
- RIDGE&POS CODE:
 - 1.HOUSING POST&WITH RIDGE
 - 2.HOUSING POST&WITHOUT RIDGE
 - 3.BOARD LOCK&WITH RIDGE
 - 4.BOARD LOCK&WITHOUT RIDGE
 - 5.BOARD LOOK(2.20)&WITH RIDGE
 - 6.BOARD LOOK(2.20)&WITHOUT RIDGE
- PLATING CODE: 1: G/F 2: 15u" Min 3: 30u" Min
- HALOGEN CODE: H: HALOGEN FREE

DIM	TOL	DIM	TOL
.x	±0.30	.x	±2'
.x	±0.25	.x	±1'
.xx	±0.20		



DEREN
SHENZHEN DEREN ELECTRONIC CO., LTD

DRAW NO.
SC2107181

CUSTOMER DRAWING	DATE
DESIGN: Chen	2021.08.19
CHECK: Bill.Lin	2021.08.19
APPROVAL: Smork.Huo	2021.08.19

TITLE:	P/N:	SHEET:	SCALE:	UNIT:
PCI-E 4.0 DIP TYPE 164PIN WITH EAR&DIP HOOK	SEE TABLE	1/3	1:1	mm

HF
Halogen Free

~~Pb~~

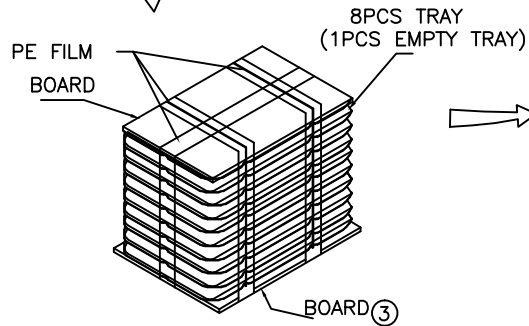
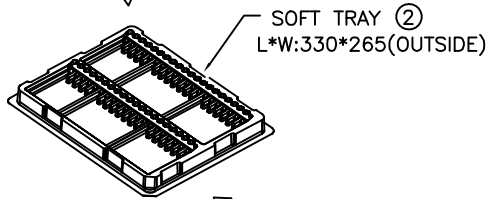
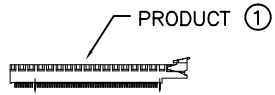

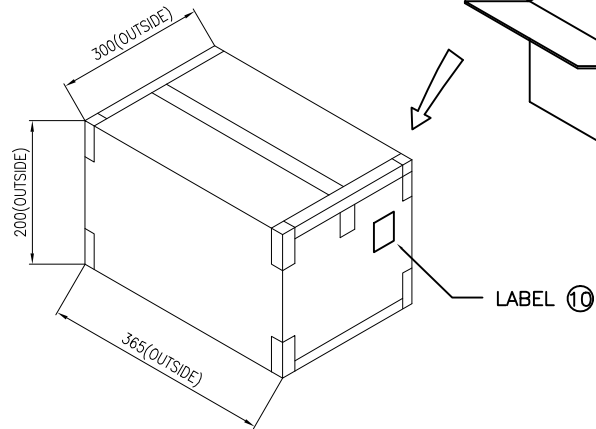
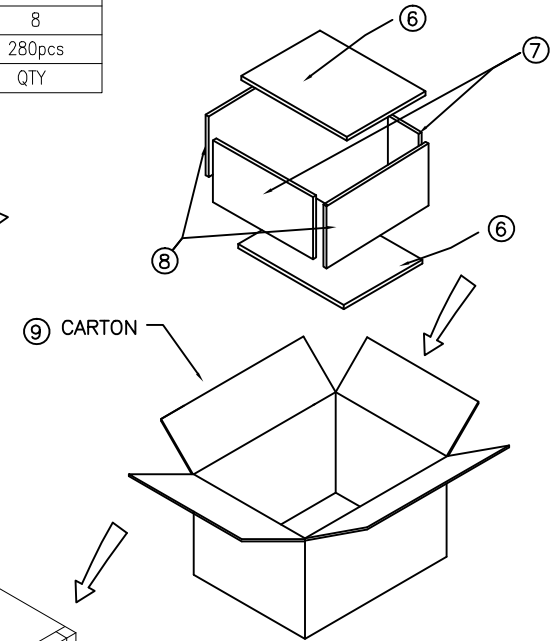
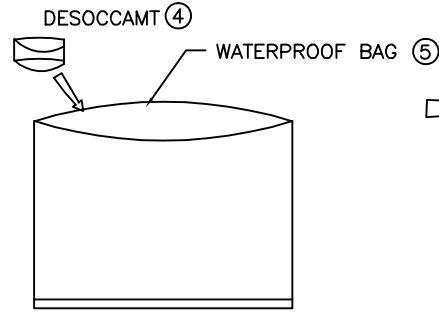

9	CARTON		365*300*200mmK=K	1
8	EPE		350*160*10mm	2
7	EPE		265*180*10mm	2
6	EPE		350*285*10mm	2
5	BAG	55-00001-03	600*600*0.10mm	1
4	DESOCAMT	-	50g/BAG	1BAG
3	BOARD		330*265mm	2
2	SOFT TRAY	-	330*265mm	8
1	CONN	-	-	280pcs
NO.	PART NAME	PART NUMBER	SPEC.	QTY



- NOTE:
1. PUT THE PRODUCTS INTO TRAY WITH DIRECTION AS THE LEFT SKETCH SHOWN,40pcs/TRAY, 7 TRAYS STACKED UP PER BUNDLE. THEN ADD AN EMPTY TRAY ON TOPSIDE.ADD A PIECE OF CARDBOARD ON THE TOP AND BOTTOM.
 2. WIND THE TWO ENDS WITH PE FILM.
 3. PUT THE PRODUCTS BUNDLED INTO WATER-PROOF PE BAG, 1BUNLDES/BAG,THEN PUT INTO THE CARTON.
 4. SEAL OUTER CARTON WITH PACKING TAPE LIKE A 'H' SHAPE.
 5. PACKAGING QUANTITY:280PCS/CARTON.

DIM	TOL	DIM	TOL
x.		x.	
.x		.x	
.xx			

		DEREN SHENZHEN DEREN ELECTRONIC CO.,LTD		CUSTOMER DRAWING		DATE	TITLE: PCI-E 4.0 DIP TYPE 164PIN WITH EAR&DIP HOOK	
				DESIGN: Chen	2021.08.19	P/N: SEE TABLE		
DRAW NO. SC2107181	CHECK: Bill.Lin	2021.08.19	SHEET: 3/3					
REV. X5	APPROVAL: Smark.Huo	2021.08.19	SCALE: 1:1	UNIT: mm				