

# HF

Halogen Free

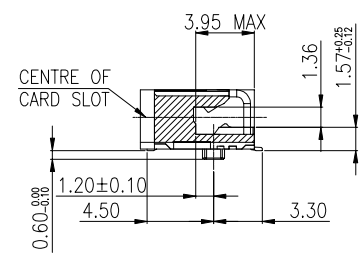

SCALE 2:1

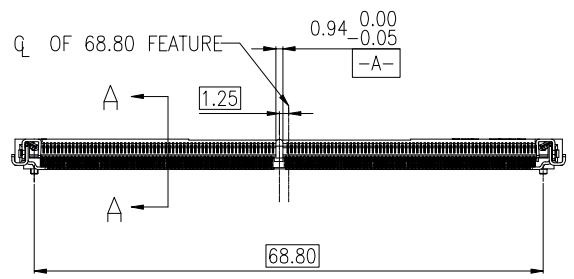
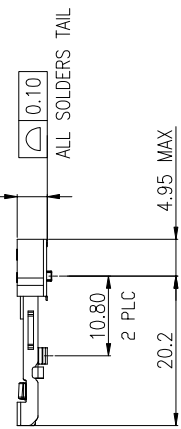
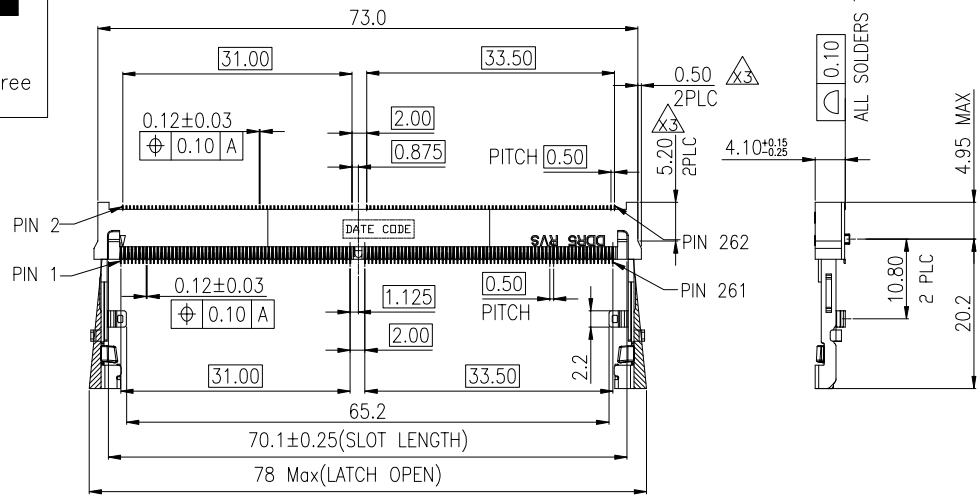
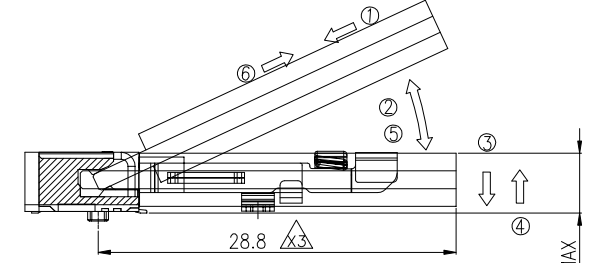

MATING/UNMATING VIEW

MATING: ① INSERTING(25°) → ② ROTATING → ③ FIXED  
UNMATING: ④ UNFIXED → ⑤ ROTATING → ⑥ WITHDRAWING

REV.	ECN NO.	LOCATION	DESCRIPTION	DATE	DESIGN
X1			PRELIMINARY DRAWING	2020.07.31	HC
X2		X2	UPDATE DRAWING	2021.02.01	HC
X3		X3	UPDATE DRAWING	2021.07.01	HC
X4		X4	UPDATE DRAWING	2022.01.10	HC

NOTES:

- MATERIAL:
  - HOUSING:LCP,UL94V-0,COLOR:BLACK.
  - CONTACT:PHOSPHOR BRONZE.
  - LATCH:STAINLESS STEEL.
- FINISH:
  - CONTACT:50u" MIN NICKEL UNDERPLATED ALL OVER.  
GOLD FALSH PLATING ON SOLDERTAIL.  
GOLD PLATING (THICKNESS SEE P/N) ON CONTACT AREA.
  - SOLDER PEG:  
50u" MIN NICKEL UNDERPLATED ALL OVER.  
100u" MIN MATTE TIN PLATING ENTIRE OVER.
- DATE CODE :YYWWDLX  
 YY: YEAR (09: 2009)  
 WW: WEEK (25: THE 25TH WEEK)  
 D: DAY (1~7: SUNDAY~SATURDAY)  
 L: LINE NUMBER OF ASSEMBLY (A: LINE A)  
 X: MANUFACTURE CODE
- RECOMMENDED STENCIL THICKNESS:0.12mm Min.

TABLE

30u"	567Y02-005H
15u"	567Y02-004H
10u"	567Y02-003H
5u"	567Y02-002H
GF	567Y02-001H
Au PLATING	DEREN P/N



**DEREN**  
SHENZHEN DEREN ELECTRONIC CO., LTD

DIM	TOL	DIM	TOL
x.	±0.50	x.'	±3'
.x	±0.35	.x'	±2'
.xx	±0.25	.xx'	±1'
.xxx	±0.15		

DRAW NO.  
SC2006739

CUSTOMER DRAWING	DATE
DESIGN: HC	2022.01.10
CHECK:	
APPROVAL:	

TITLE:	P/N:
DDR5 SO DIMM 262PIN 4.0H RVS METAL LATCH ASSY	SEE TABLE
SHEET: 1/3	
SCALE: 1:1	UNIT: mm

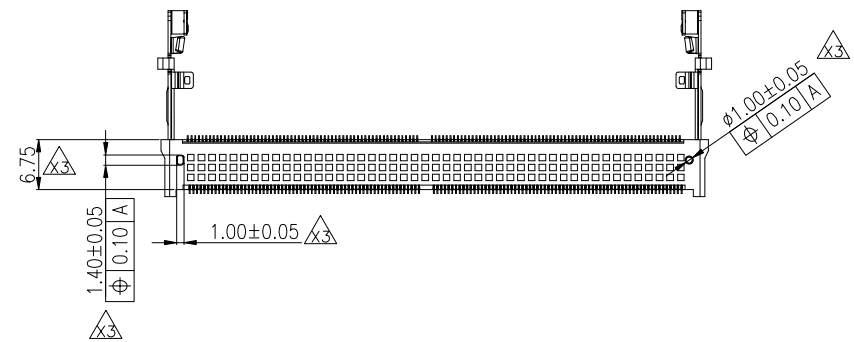

# HF

Halogen Free



REV.	ECN NO.	LOCATION	DESCRIPTION	DATE	DESIGN
X1			PRELIMINARY DRAWING	2020.07.31	HC
X2			UPDATE DRAWING	2021.02.01	HC
X3			UPDATE DRAWING	2021.07.01	HC
X4			UPDATE DRAWING	2022.01.10	HC

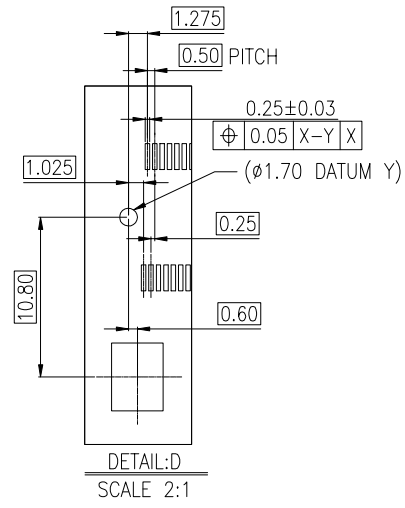
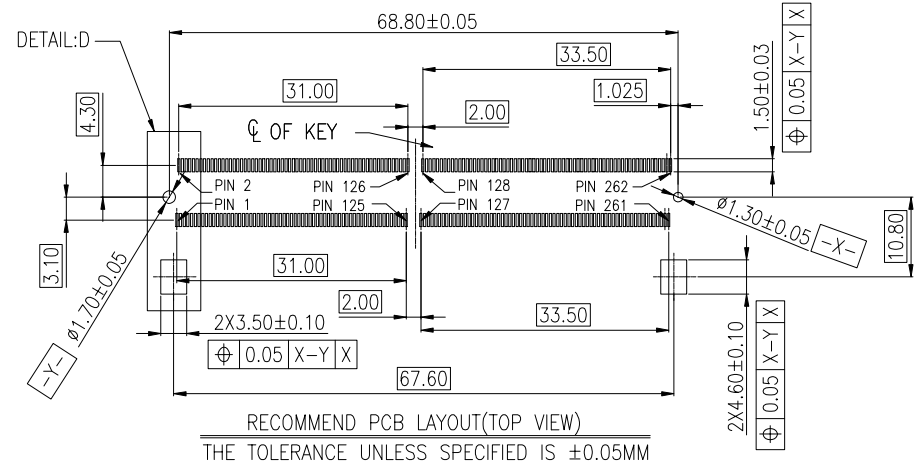
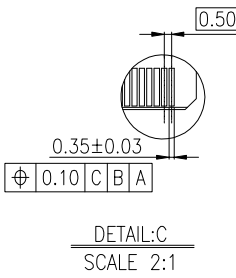
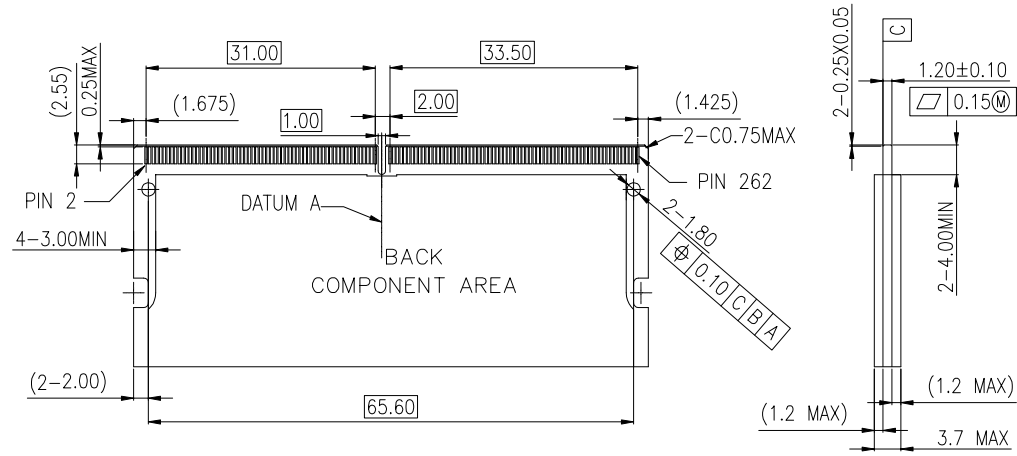
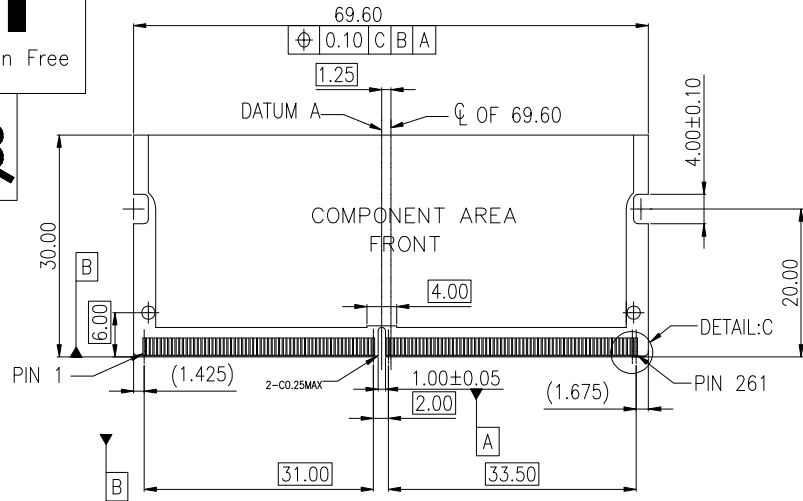

DIM	TOL	DIM	TOL
.x	±0.50	.x'	±3°
.x	±0.35	.x'	±2°
.xx	±0.25	.xx'	±1°
.xxx	±0.15		

**DEREN**  
SHENZHEN DEREN ELECTRONIC CO., LTD

CUSTOMER DRAWING		DATE	TITLE: DDR5 SO DIMM 262PIN 4.0H RVS METAL LATCH ASSY
DESIGN: HC	2022.01.10	P/N: SEE TABLE	
CHECK:		SHEET: 2/3	
APPROVAL:		SCALE: 1:1	UNIT: mm

DRAW NO. SC2006739

REV. X4

# HF

Halogen Free

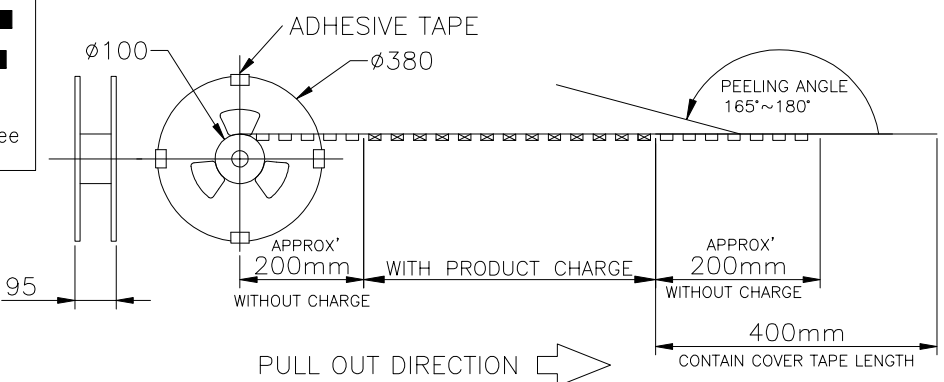

REV.	ECN NO.	LOCATION	DESCRIPTION	DATE	DESIGN
X1			PRELIMINARY DRAWING	2020.07.31	HC
X2		△2	UPDATE DRAWING	2021.02.01	HC
X3		△3	UPDATE DRAWING	2021.07.01	HC
X4		△4	UPDATE DRAWING	2022.01.10	HC

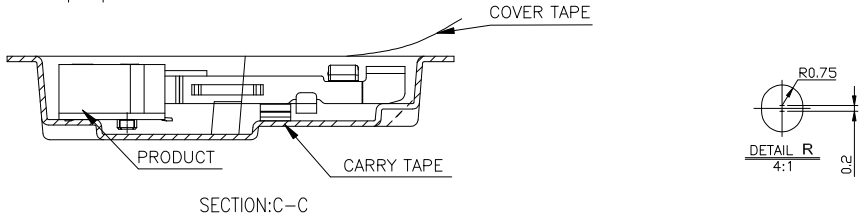
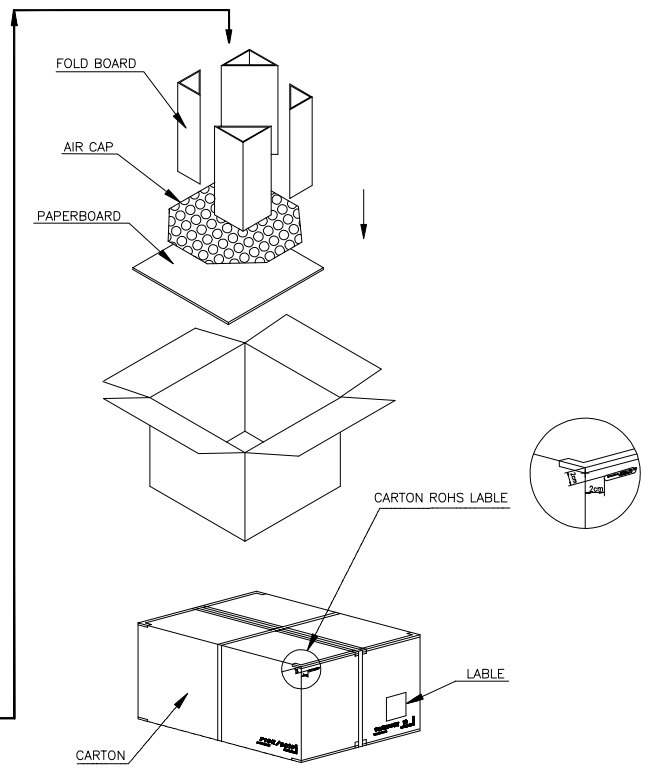
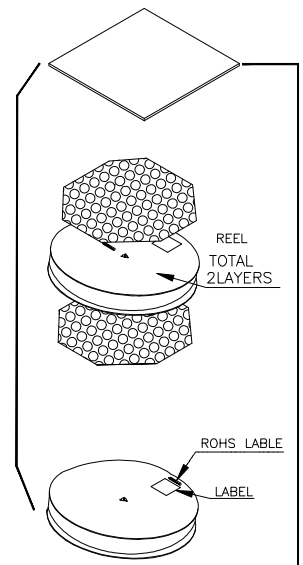
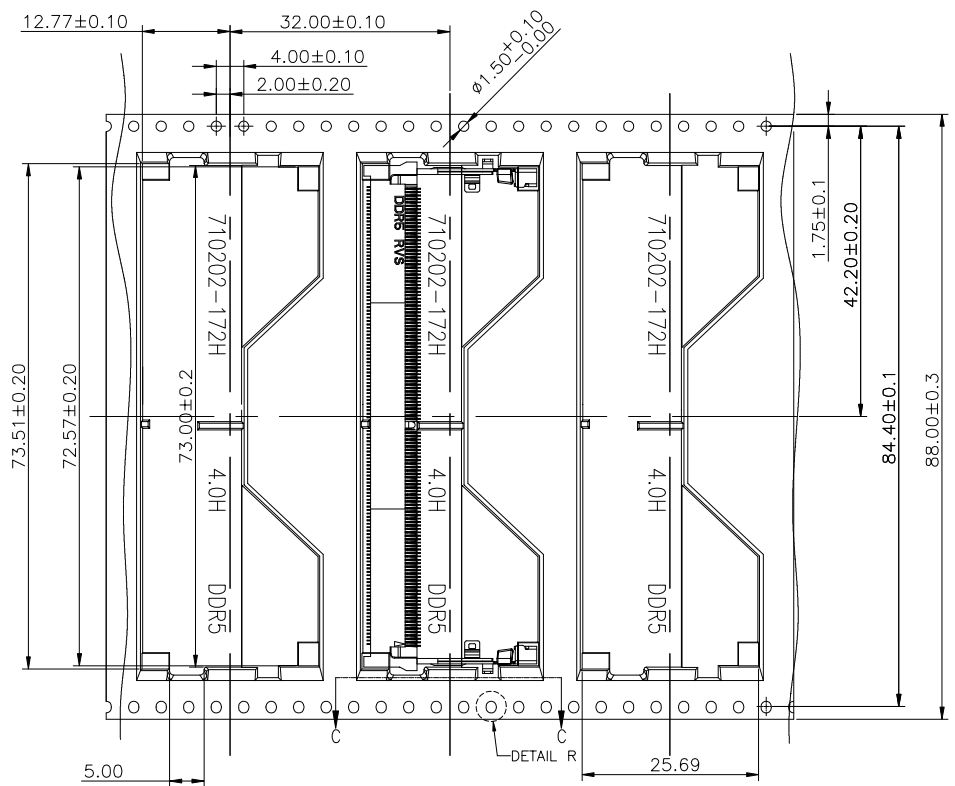

△	500	2	1000	SEE P/N
	PCS/REEL	REEL/CARTON	PCS/CARTON	PART NUMBER

DIM	TOL	DIM	TOL
x.	±0.50	x.'	±3'
.x	±0.35	.x'	±2'
.xx	±0.25	.xx'	±1'
.xxx	±0.15		



**DEREN**  
SHENZHEN DEREN ELECTRONIC CO., LTD

DRAW NO.	DESIGN:	HC	DATE	2022.01.10	TITLE:	DDR5 SO DIMM 262PIN 4.0H RVS METAL LATCH ASSY
SC2006739	CHECK:				P/N:	SEE TABLE
REV. X4	APPROVAL:				SHEET:	3/3
					SCALE:	1:1
					UNIT:	mm