

# HF

Halogen Free

REV.	ECN NO.	LOCATION	DESCRIPTION	DATE	DESIGN
X1			INITIAL RELEASE	2020.07.24	Liangkeyao

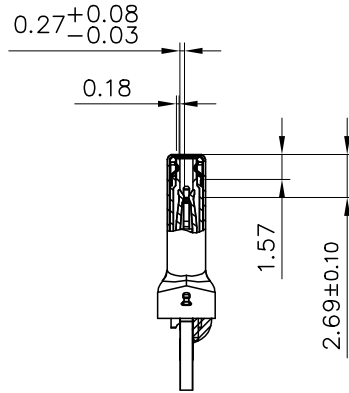
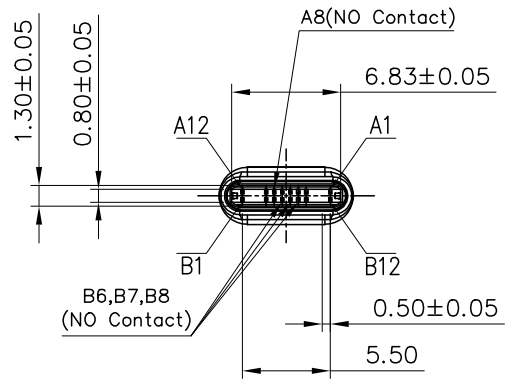

SECTION B-B  
SCALE 1:1  
(WITH EMI SPRING)

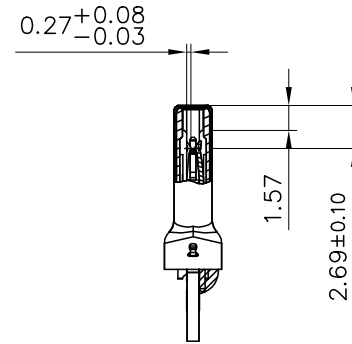

SECTION B-B  
SCALE 1:1  
(WITHOUT EMI SPRING)

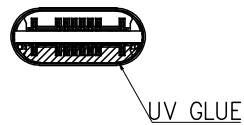
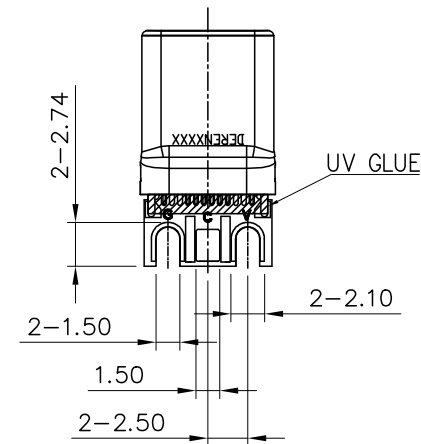
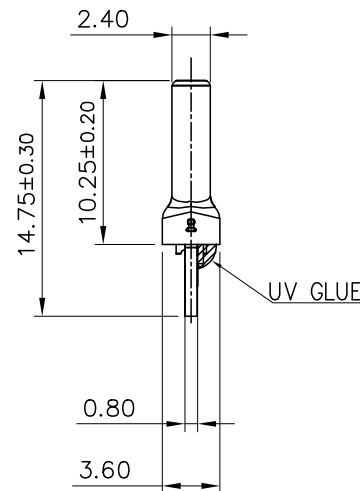
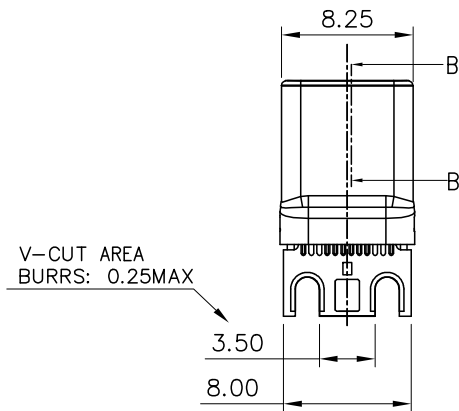
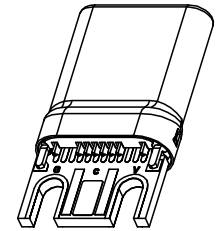

DIM	TOL	DIM	TOL
.x	±0.30	.x	±2'
.x	±0.25	.x	±1'
.xx	±0.15		

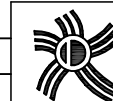

**DEREN**

SHENZHEN DEREN ELECTRONIC CO., LTD

CUSTOMER DRAWING		DATE	TITLE: UC PLUG WITH PCB (POWER CORD 65W)12P ASSY	
DESIGN:	Liangkeyao	2020.07.24	P/N: 40-42415-CC08xTxxxx	
CHECK:			SHEET:	1/3
REV.	X1	APPROVAL:	SCALE:	1:1
			UNIT:	mm

**HF**  
Halogen Free

REV.	ECN NO.	LOCATION	DESCRIPTION	DATE	DESIGN
X1			INITIAL RELEASE	2020.07.24	Liangkeyao

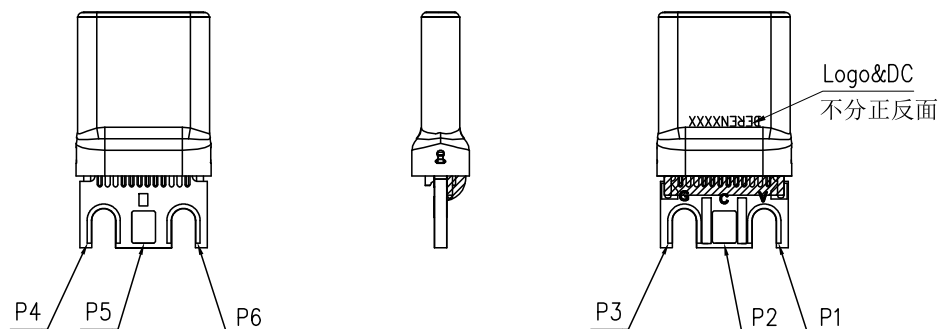

CONTACT FIGURE:

CONN PIN	PCB PIN
A1,A12,B1,B2,SHELL	P3,P6
A5	P2,P5
A4,A9,B4,B9	P1,P4
A6,A7	SHORT

TIN THICK REQUEST:  
ALL CABLE PAD WITH TIN

PINS DESCRIPTION  
PLUG FRONT VIEW

A12	A11	A10	A9	A8	A7	A6	A5	A4	A3	A2	A1
GND	/	/	VBus	/	D-	D+	CC	VBus	/	/	GND
GND	/	/	VBus	Vconn	/	/	/	VBus	/	/	GND
B1	B2	B3	B4	B5	B6	B7	B8	B9	B10	B11	B12

DIM	TOL	DIM	TOL
x.	±0.30	x.	±2'
.x	±0.25	.x	±1'
.xx	±0.15		

	<b>DEREN</b> SHENZHEN DEREN ELECTRONIC CO., LTD		
	CUSTOMER DRAWING	DATE	TITLE: UC PLUG WITH PCB (POWER CORD 65W)12P ASSY
DRAW NO. ***	DESIGN: Liangkeyao	2020.07.24	P/N: 40-42415-CC08xTxxxx
REV. X1	CHECK:		SHEET: 2/3
APPROVAL:			SCALE: 1:1 UNIT: mm

