

HF

Halogen Free

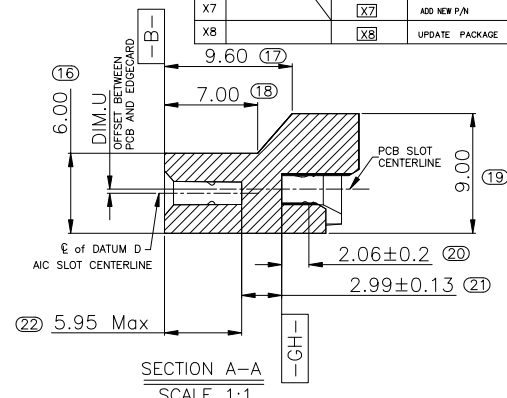

| REV. | ECN NO. | LOCATION | DESCRIPTION | DATE | DESIGN |
|------|---------|----------|-----------------------------|------------|-----------|
| X1 | | | INITIAL RELEASE | 2020.02.24 | Cay Zhao |
| X2 | | | UPDATE | 2020.04.24 | Cay Zhao |
| X3 | | | UPDATE PACKING SPEC | 2020.05.20 | Cay Zhao |
| X4 | | | ADD PCB THICKNESS TYPE | 2020.06.19 | Cay Zhao |
| X5 | | | UPDATE | 2020.07.21 | Cay Zhao |
| X6 | | | UPDATE P/N INF. AND PACKAGE | 2020.08.07 | Cay Zhao |
| X7 | | X7 | ADD NEW P/N | 2021.01.12 | MikeJiang |
| X8 | | X8 | UPDATE PACKAGE | 2021.03.26 | MikeJiang |

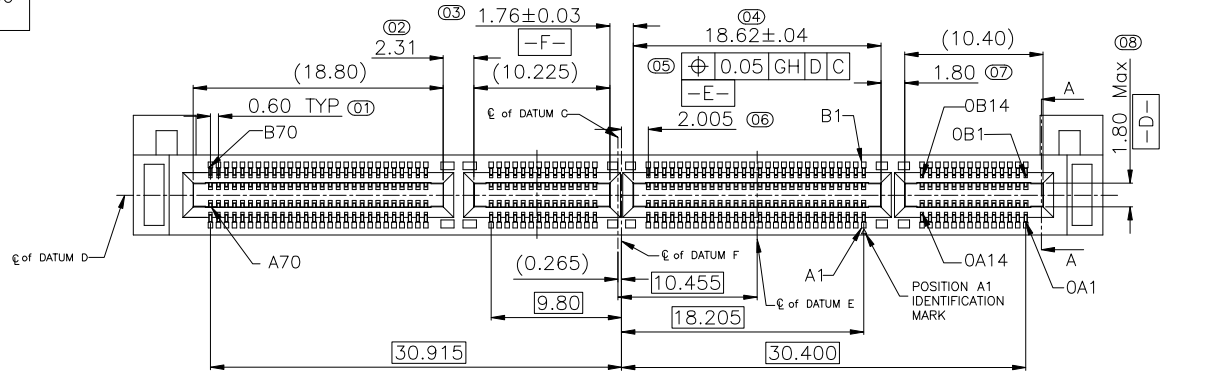

SECTION A-A
SCALE 1:1

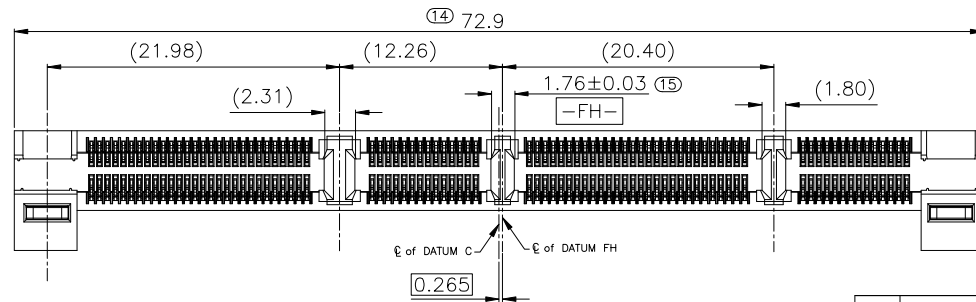
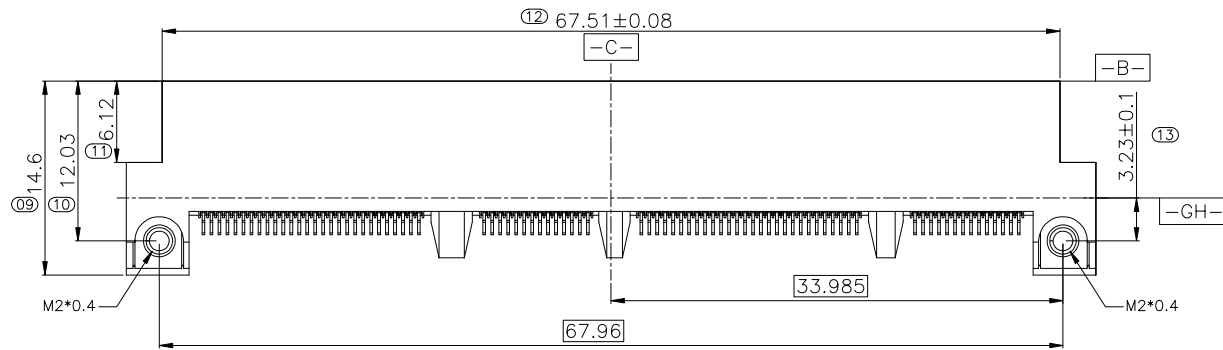

PRODUCT MEETS CONTROLLED SUBSTANCES SPEC. ROHS 2.0

NOTES:

- MATERIAL:
 - HOUSING: HIGH TEMPERATURE PLASTIC. UL94V-0 COLOR:BLACK
 - CONTACT: COPPER ALLOY
 - NUT: STEEL
- FINISH:
 - CONTACT:
 - GOLD PLATING(SEE P/N INFORMATION) ON CONTACT AREA;
 - GOLD FLASH PLATING ON SOLDER TAIL AREA;
 - 50μ"MIN. NICKEL UNDERPLATING OVERALL.
- RECOMMENDED PCB THICKNESS :DIM.T SEE P/N INFORMATION.
- MATING CARD THICKNESS: 1.57±0.13mm.
- REFLOW SOLDER CAPABLE TO 260°C MAX.
- PART NUMBER INFORMATION:

X7 5653E5-001H X X X X

GREEN CODE:
H:HALOGEN FREE
R: HALOGEN

PACKAGE CODE:
T: SOFT TRAY
H: HARD TRAY

HOUSING COLOR CODE:
0: BLACK

PLATING CODE:
0:GOLD FLASH
1:GOLD 15u"
2:GOLD 30u"

PCB THICKNESS DIM.T AND OFFSET DIM.U:
0: DIM.T=1.57±0.15mm, OFFSET DIM.U=0.0mm
1: DIM.T=1.93±0.19mm, OFFSET DIM.U=0.30mm
2: DIM.T=2.36±0.23mm, OFFSET DIM.U=0.0mm

MATING CARD THICKNESS:
0: 1.57±0.13mm

5653E5-001HX010T

| DIM | TOL | DIM | TOL |
|-----|-------|-----|-----|
| x. | ±0.30 | x. | ±2° |
| .x | ±0.25 | .x | ±1° |
| .xx | ±0.15 | | |



DEREN
SHENZHEN DEREN ELECTRONIC CO., LTD

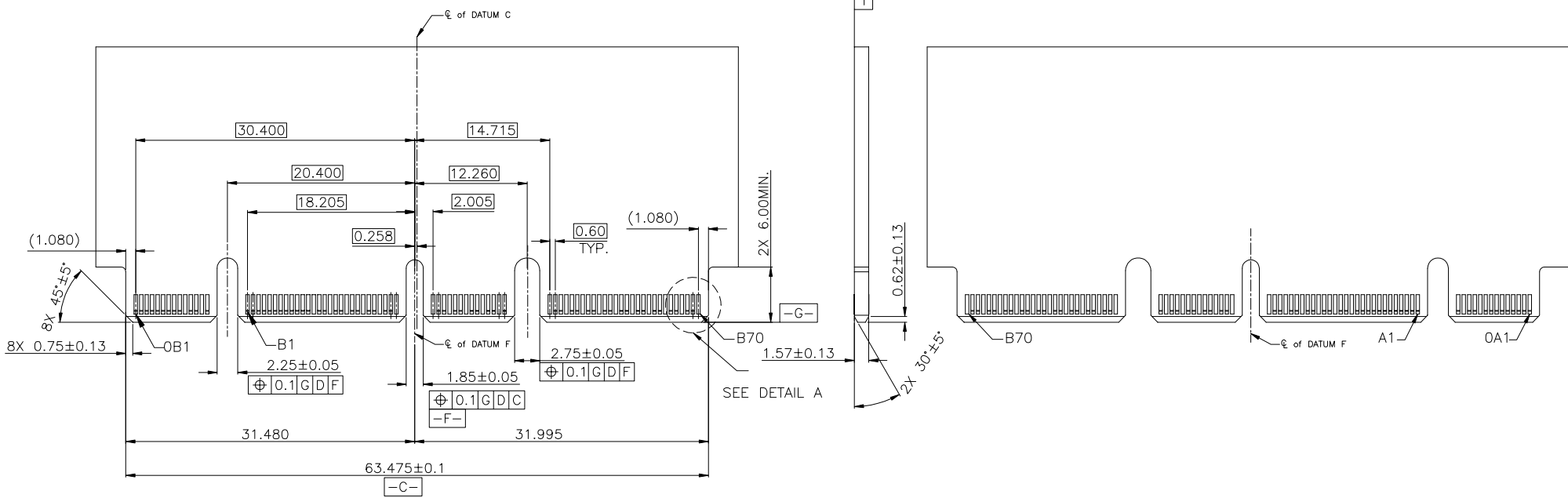

| | | |
|------------------|---------------------|---|
| CUSTOMER DRAWING | DATE | TITLE: GEN 2 4C+ 168PIN STRADDLE MOUNT CONN |
| DESIGN: Cay Zhao | 2021.03.26 | P/N: SEE P/N INFORMATION |
| CHECK: Bill Lin | 2021.03.26 | SHEET: 1/5 |
| REV. X8 | APPROVAL: Smark Huo | 2021.03.26 |
| | | SCALE: 1:1 |
| | | UNIT: mm |

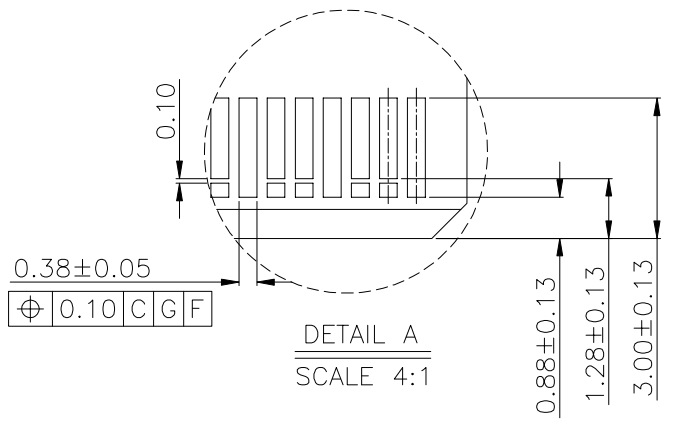

RECOMMENDED AIC 4C+ MATING CARD LAYOUT
TOLERANCE ±0.05



| DIM | TOL | DIM | TOL |
|-----|-------|-----|-----|
| x. | ±0.30 | x. | ±2° |
| .x | ±0.25 | .x | ±1° |
| .xx | ±0.15 | | |

| | | | | |
|---|---------------------|------------|---|---|
|  | DEREN | | SHENZHEN DEREN ELECTRONIC CO., LTD | |
| | CUSTOMER DRAWING | DATE | TITLE: GEN Z 4C+ 168PIN STRADDLE MOUNT CONN | |
| | DESIGN: Cay Zhao | 2021.03.26 | P/N: SEE P/N INFORMATION | |
| | CHECK: Bill Lin | 2021.03.26 | SHEET: 2/5 |  |
| REV. X8 | APPROVAL: Smark Huo | 2021.03.26 | SCALE: 1:1 | UNIT: mm |

1 2 3 4 5 6 7 8

A

B

C

D

E

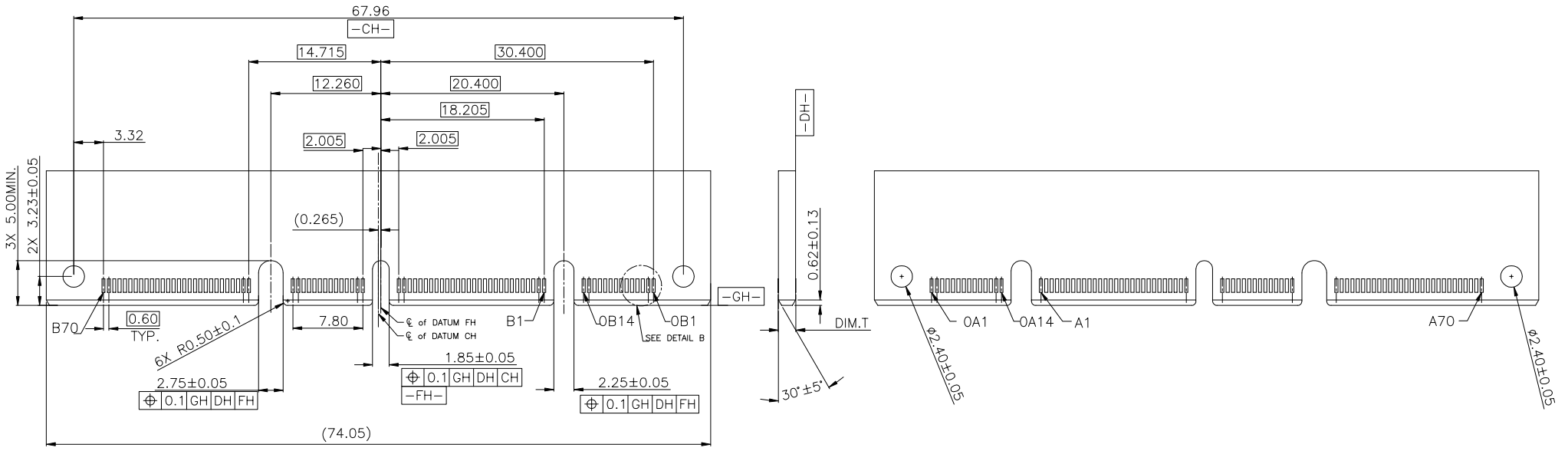

RECOMMENDED PCB LAYOUT
TOLERANCE ±0.05

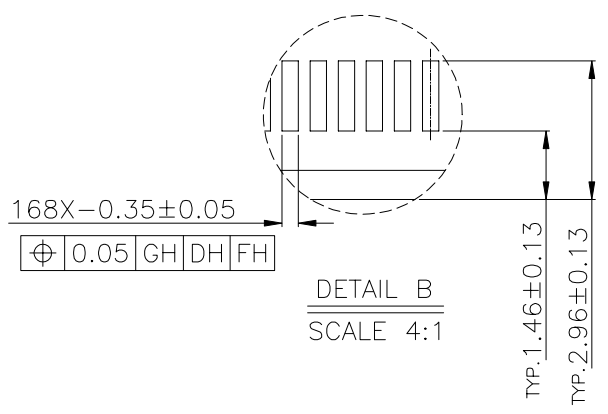

DETAIL B
SCALE 4:1

| DIM | TOL | DIM | TOL |
|-----|-------|-----|-----|
| x. | ±0.30 | x. | ±2° |
| .x | ±0.25 | .x | ±1° |
| .xx | ±0.15 | | |



DEREN
SHENZHEN DEREN ELECTRONIC CO., LTD

| CUSTOMER DRAWING | | DATE | TITLE: GEN Z 4C+ 168PIN STRADDLE MOUNT CONN | |
|------------------|----------|------------|---|----------|
| DESIGN: | Cay Zhao | 2021.03.26 | P/N: SEE P/N INFORMATION | |
| CHECK: | Bill Lin | 2021.03.26 | SHEET: 3/5 | |
| APPROVAL: | Smak Huo | 2021.03.26 | SCALE: 1:1 | UNIT: mm |

DRAW NO.
SC1906005

REV. X8

1 2 3 4 5 6 7 8

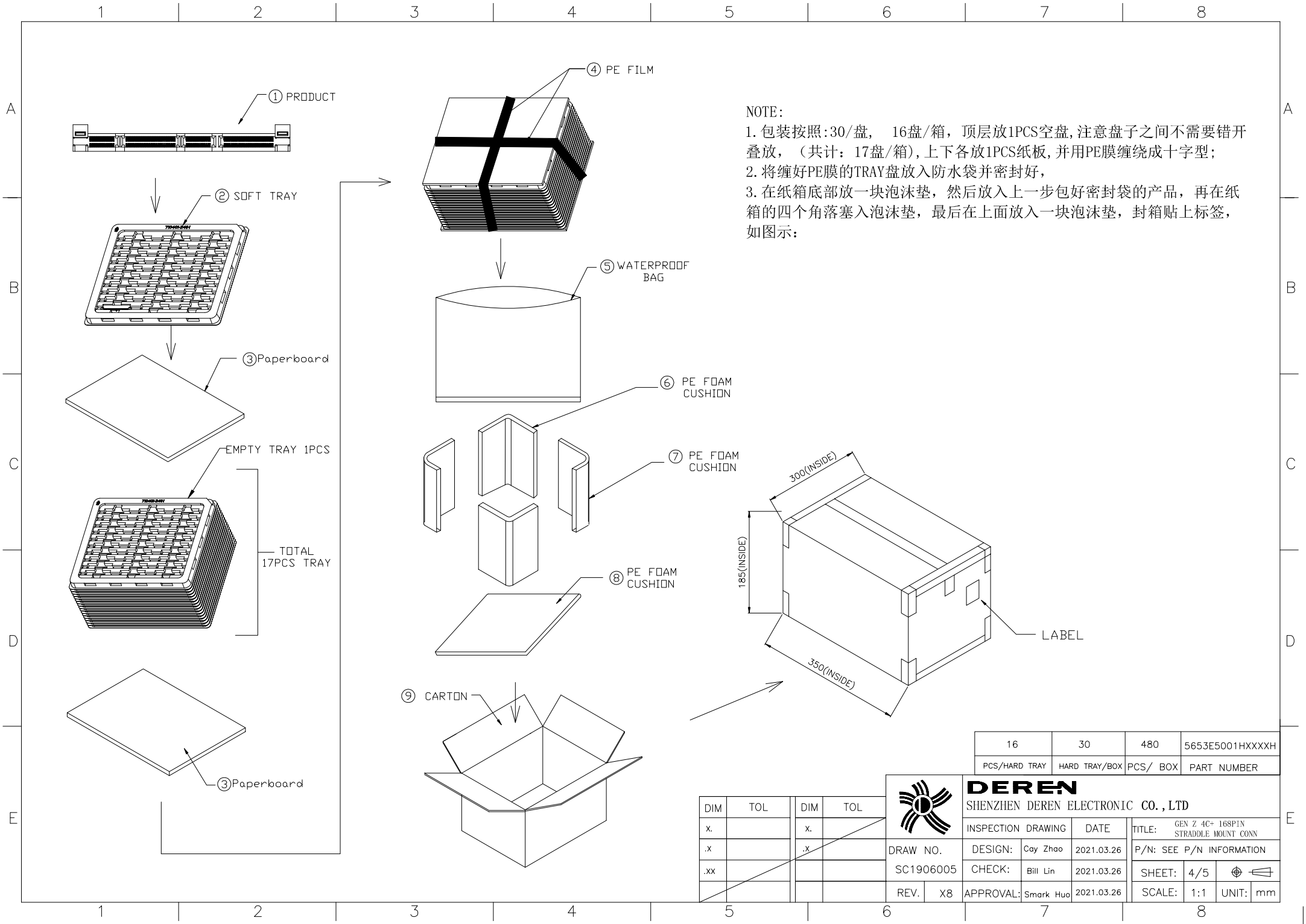

NOTE:
 1. 包装按照:30/盘, 16盘/箱, 顶层放1PCS空盘, 注意盘子之间不需要错开叠放, (共计: 17盘/箱), 上下各放1PCS纸板, 并用PE膜缠绕成十字型;
 2. 将缠好PE膜的TRAY盘放入防水袋并密封好,
 3. 在纸箱底部放一块泡沫垫, 然后放入上一步包好密封袋的产品, 再在纸箱的四个角落塞入泡沫垫, 最后在上面放入一块泡沫垫, 封箱贴上标签, 如图示:

| | | | |
|---------------|---------------|----------|-----------------|
| 16 | 30 | 480 | 5653E5001HXXXXH |
| PCS/HARD TRAY | HARD TRAY/BOX | PCS/ BOX | PART NUMBER |

| DIM | TOL | DIM | TOL |
|-----|-----|-----|-----|
| x. | | x. | |
| .x | | .x | |
| .xx | | | |

DEREN
 SHENZHEN DEREN ELECTRONIC CO., LTD

| | | | |
|---------------------|------------------|------------|---|
| INSPECTION | DRAWING | DATE | TITLE: GEN Z 4C+ 168PIN STRADDLE MOUNT CONN |
| DRAW NO. SC1906005 | DESIGN: Cay Zhao | 2021.03.26 | P/N: SEE P/N INFORMATION |
| REV. X8 | CHECK: Bill Lin | 2021.03.26 | SHEET: 4/5 |
| APPROVAL: Smark Hua | 2021.03.26 | SCALE: 1:1 | UNIT: mm |

1 2 3 4 5 6 7 8

A
B
C
D
E

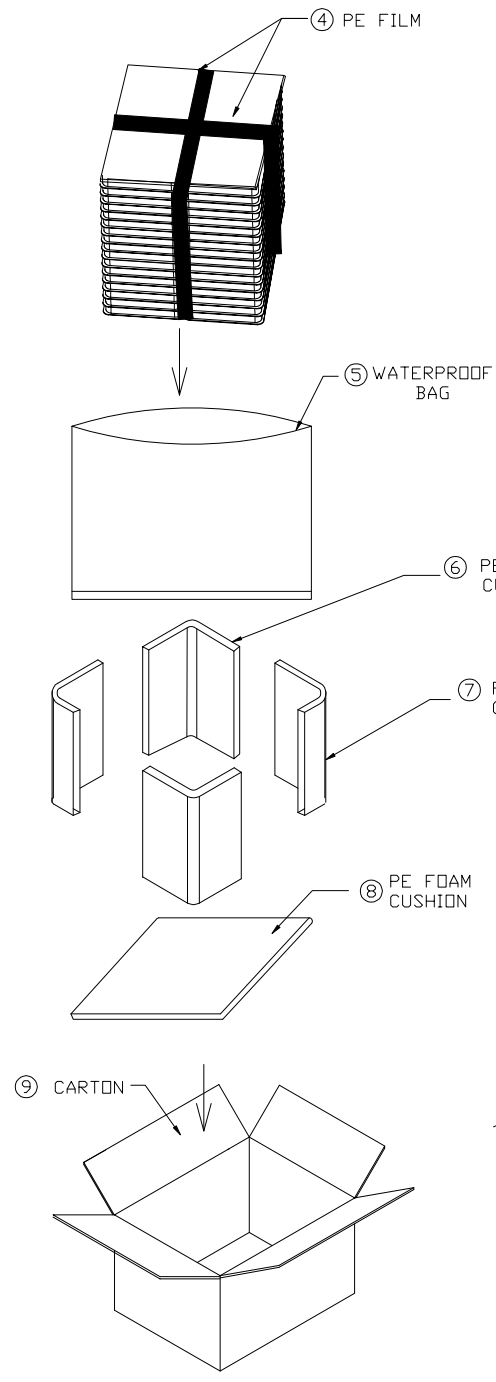
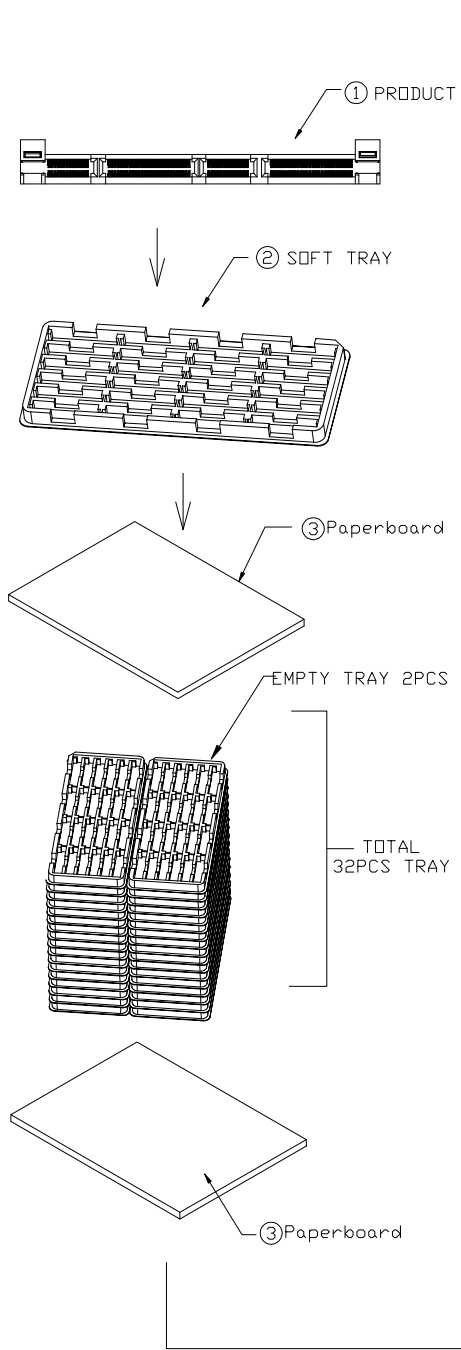

NOTE:

1. PUT THE PRODUCTS INTO TRAY 30PCS/TRAY, 24 TRAYS STACKED UP PER BUNDLE. THEN ADD AN EMPTY TRAY ON TOPSIDE.
2. WIND THE TWO ENDS WITH PE FILM AND THEN PUT INTO THE WATERPROOF BAG.
3. PUT ONE PE FOAM UNDER THE CARTON AND ONE ON TOP OF CARTON
4. SEAL OUTER CARTON WITH PACKING TAPE LIKE A 'H' SHAPE

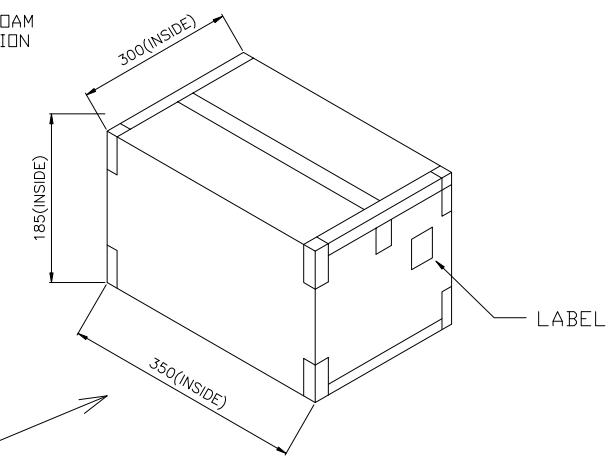

| | | | |
|---------------|---------------|----------|-----------------|
| 24 | 34 | 768 | 5653E5001HXXXXH |
| PCS/HARD TRAY | HARD TRAY/BOX | PCS/ BOX | PART NUMBER |

| DIM | TOL | DIM | TOL |
|-----|-----|-----|-----|
| x. | | x. | |
| .x | | .x | |
| .xx | | | |

DEREN

SHENZHEN DEREN ELECTRONIC CO., LTD

| | | | |
|---------------------|------------------|------------|---|
| INSPECTION | DRAWING | DATE | TITLE: GEN Z 4C+ 16SPIN STRADDLE MOUNT CONN |
| DRAW NO. SC1906005 | DESIGN: Cay Zhao | 2021.03.26 | P/N: SEE P/N INFORMATION |
| REV. X8 | CHECK: Bill Lin | 2021.03.26 | SHEET: 5/5 |
| APPROVAL: Smark Huo | 2021.03.26 | SCALE: 1:1 | UNIT: mm |

1 2 3 4 5 6 7 8