

# HF

Halogen Free

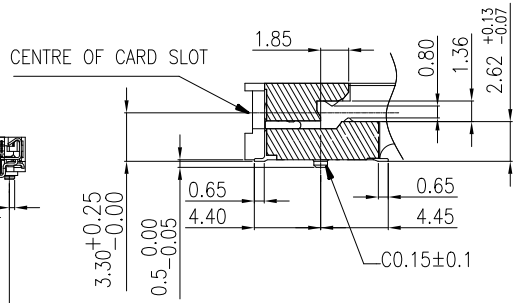

SECTION:A-A  
SCALE 2:1

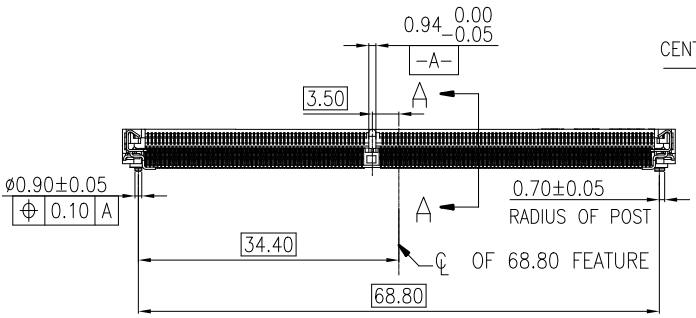
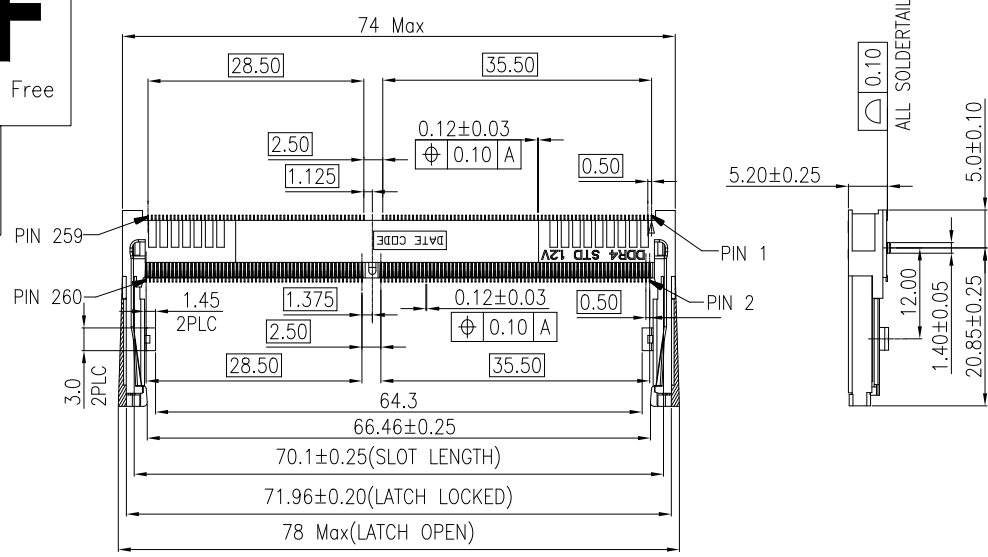
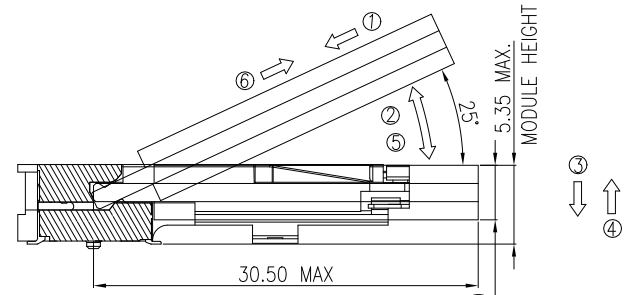

MATING/UNMATING VIEW  
SCALE 2:1

MATING: ① INSERTING(25°) → ② ROTATING → ③ FIXED  
UNMATING: ④ UNFIXED → ⑤ ROTATING → ⑥ WITHDRAWING

TABLE 2

30u" Au	40-42272-26005RHF	.x	±0.35
15u" Au	40-42272-26004RHF	.xx	±0.25
10u" Au	40-42272-26003RHF	.xxx	±0.15
5u" Au	40-42272-26002RHF		
GF	40-42272-26001RHF		
PLATING THICKNESS	DEREN P/N		

DIM	TOL	DIM	TOL
x	±3'	x'	±2'
xx	±2'	x''	±1'
xxx	±1'		



**DEREN**  
SHENZHEN DEREN ELECTRONIC CO., LTD

C-DWG	TY	DATE	TITLE: DDR4 SO DIMM 260P 5.2H STD C-DWG
DESIGN:	Wang.lie	9/29'16	P/N: SEE TABLE 2
CHECK:	Bill.lin	9/29'16	SHEET: 1/3
APPROVAL:	Bill.lin	9/29'16	SCALE: 1:1 UNIT: mm

NOTES:  
1.MATERIAL:

- 1.1 HOUSING:LCP,UL94V-0,COLOR:BLACK.
- 1.2 CONTACT:PHOSPHOR BRONZE.
- 1.3 SOLDER PEG AND LATCH:STAINLESS STEEL.
- 2. FINISH:
- 2.1 CONTACT: 50u" MIN NICKEL UNDERPLATED ALL OVER. GOLD FLASH PLATING ON SOLDERTAIL. GOLD PLATING (THICKNESS SEE TABLE) ON CONTACT AREA.
- 2.2 SOLDER PEG: 50u" MIN NICKEL UNDERPLATED ALL OVER. AU 2u" MAX ON SOLDERTAIL.
- 3. DATE CODE : YYWDLX  
YY: YEAR (09: 2009)  
WW: WEEK (25: THE 25TH WEEK)  
D: DAY (1~7: SUNDAY~SATURDAY)  
L: LINE NUMBER OF ASSEMBLY (A: LINE A)  
X: MANUFACTURE CODE
- 4. PART NUMBER DESCRIPTION:  
40-42272-2600XRHF

- HALOGEN CODE:  
HF:HALOGEN FREE
- R: TAPE & REEL PACKING
- PLATING CODE:  
1: GF 2: Au5u" 3: Au10u"  
4: Au15u" 5: Au30u"
- RESERVED
- PIN NUMBER CODE: 260 PINS

DRAW NO. SC2107740-10

REV. B

# HF

Halogen Free



REV.	ECN NO.	LOCATION	DESCRIPTION	DATE	DESIGN
A2			REVISE	8/18'15	Wang.lie
B			REVISE	9/29'16	Wang.lie

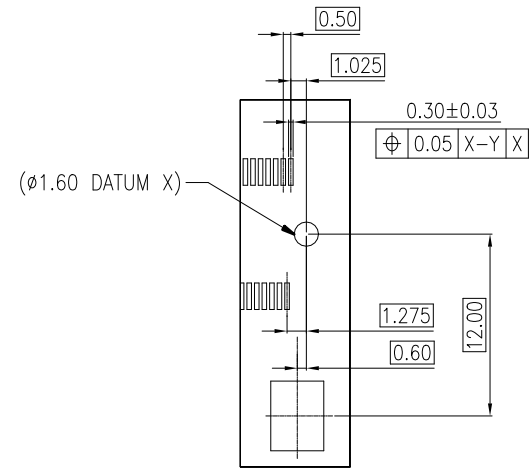
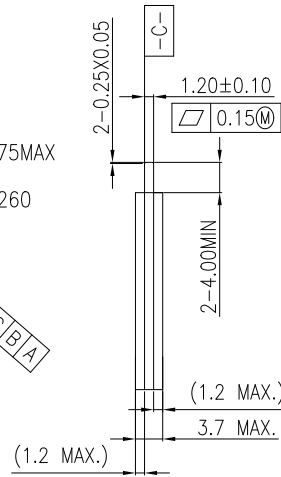
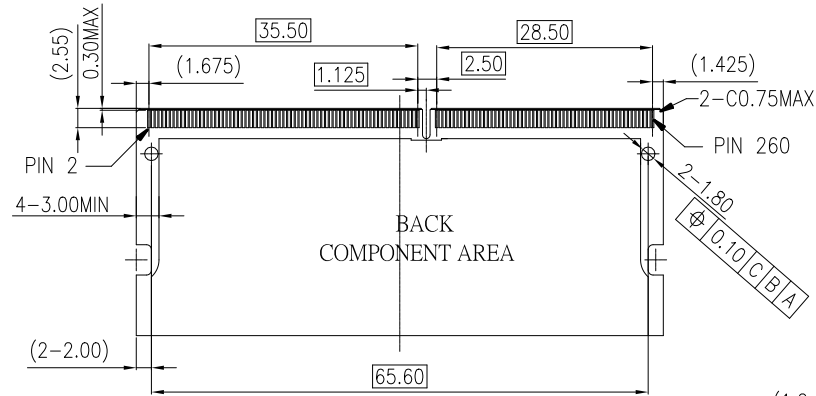
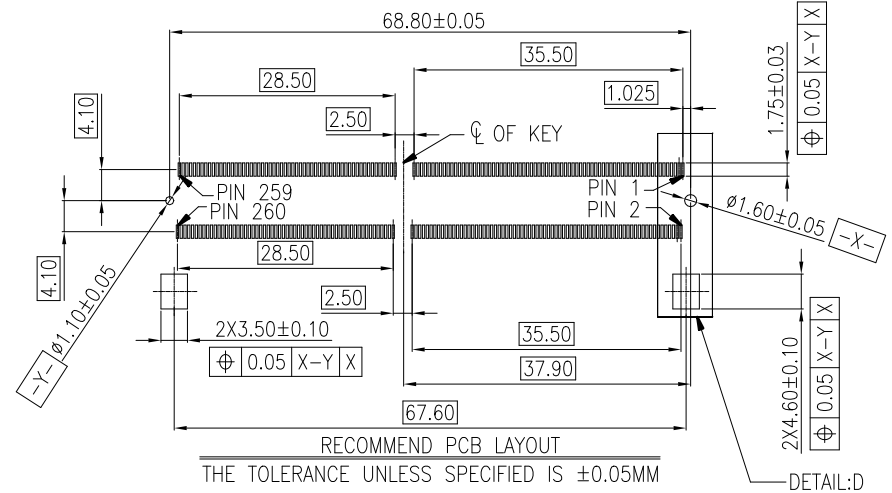
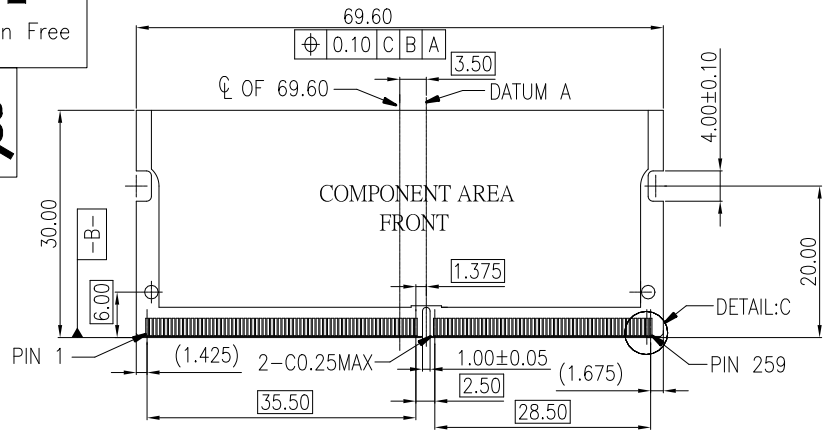

DETAIL:D  
 SCALE 2:1

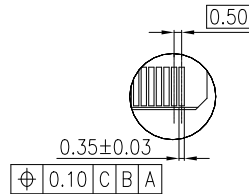

DETAIL:C  
 SCALE 2:1

DIM	TOL	DIM	TOL
.x	±0.35	x.*	±3*
.xx	±0.25	.x*	±2*
.xxx	±0.15	.xx*	±1*

**DEREN**  
 SHENZHEN DEREN ELECTRONIC CO., LTD

C-DWG	TY	DATE	TITLE: DDR4 SO DIMM 260P 5.2H STD C-DWG
DESIGN: Wang.lie	9/29'16	P/N: SEE TABLE 2	
CHECK: Bill.lin	9/29'16	SHEET: 2/3	
APPROVAL: Bill.lin	9/29'16	SCALE: 1:1	UNIT: mm

DRAW NO. SC2107740-10

REV. B

# HF

Halogen Free



REV.	ECN NO.	LOCATION	DESCRIPTION	DATE	DESIGN
A2			REVISE	8/18'15	Wang.lie
B			REVISE	9/29'16	Wang.lie

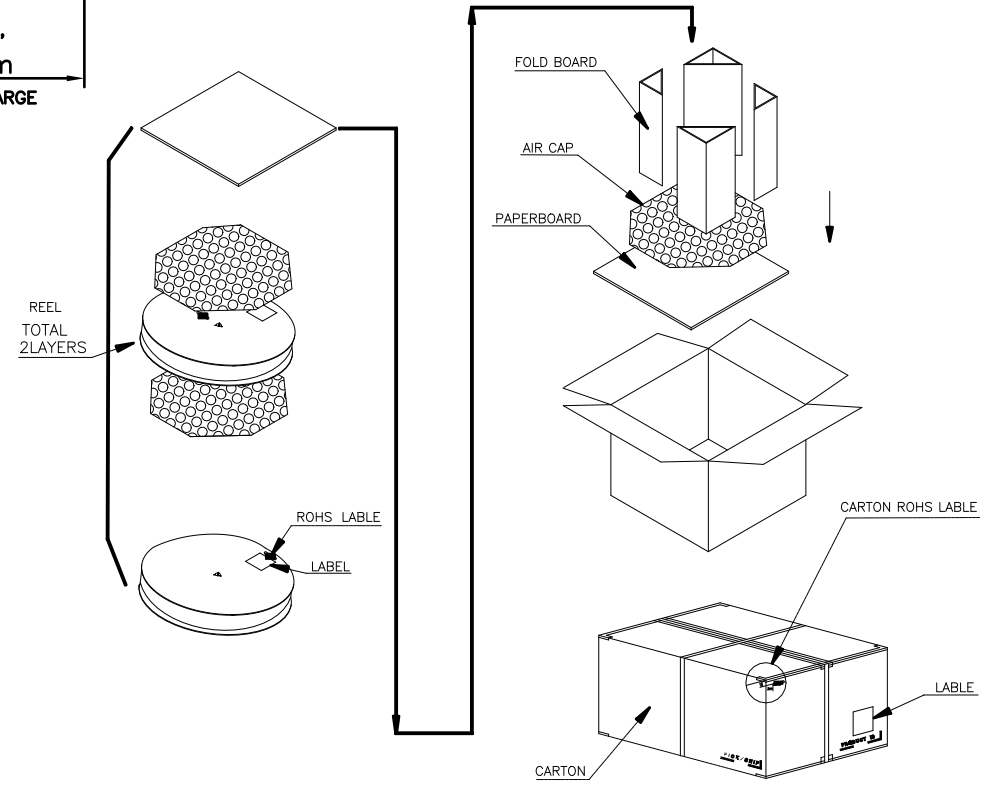
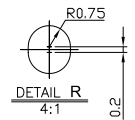
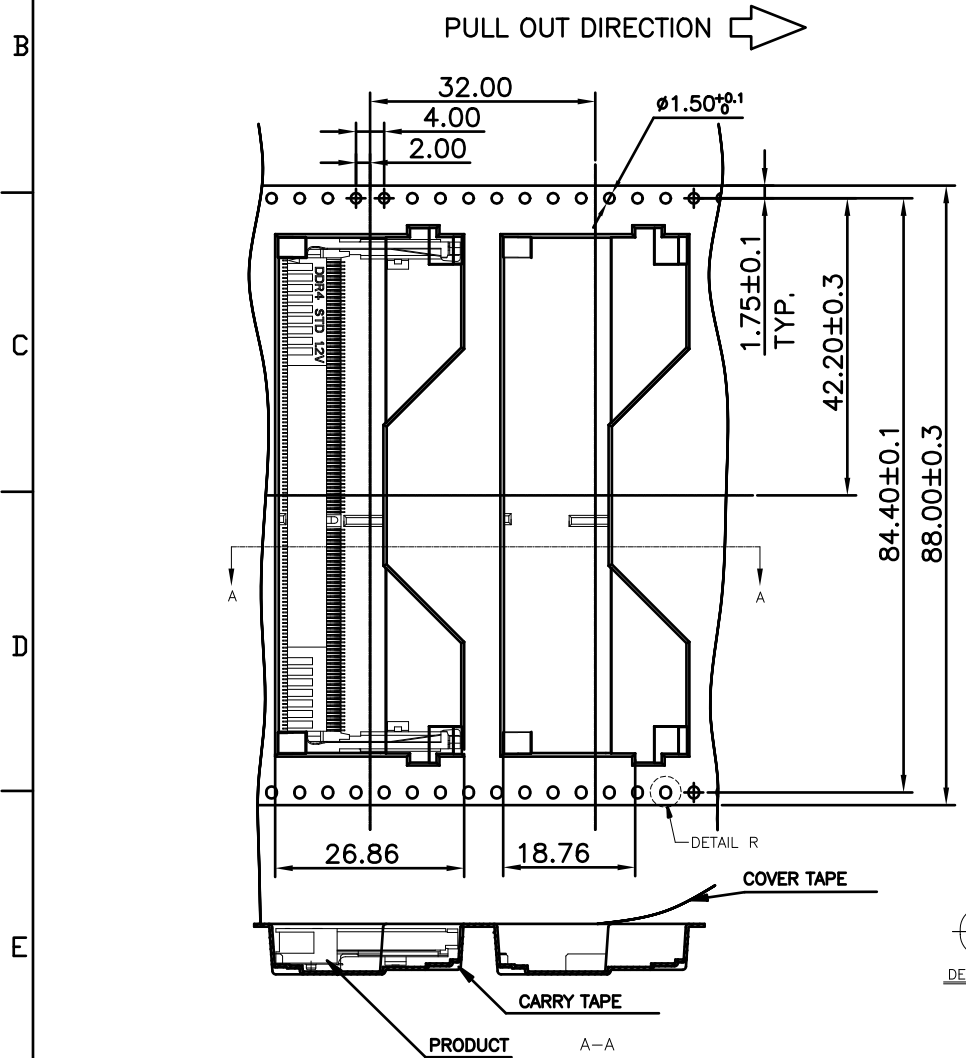
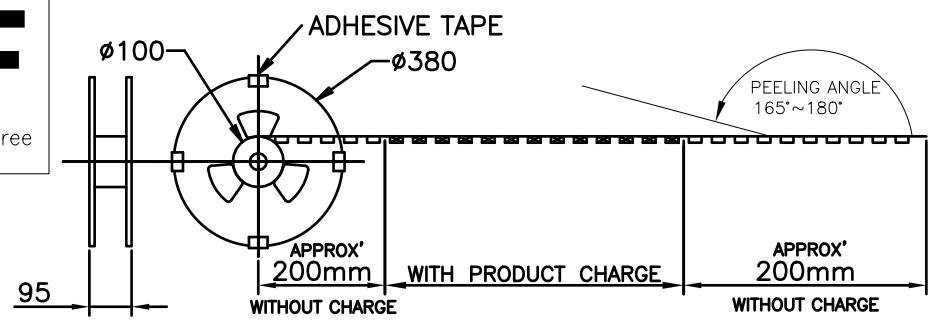

400	2	800	40-42272-2600XRHF
PCS/REEL	REEL/CARTON	PCS/CARTON	PART NUMBER

DIM	TOL	DIM	TOL
.X	±0.35	.X'	±3'
.XX	±0.25	.X''	±2'
.XXX	±0.15	.XX'	±1'



**DEREN**  
SHENZHEN DEREN ELECTRONIC CO., LTD

DRAW NO. SC2107740-10  
REV. B

C-DWG	TY	DATE
DESIGN:	Wang.lie	9/29'16
CHECK:	Bill.lin	9/29'16
APPROVAL:	Bill.lin	9/29'16

TITLE:	DDR4 SD DIMM 260P 5.2H STD C-DWG
P/N:	SEE TABLE 2
SHEET:	3/3
SCALE:	1:1
UNIT:	mm